

STAV RUNES NOTEBOOK

A Beginner's Guide

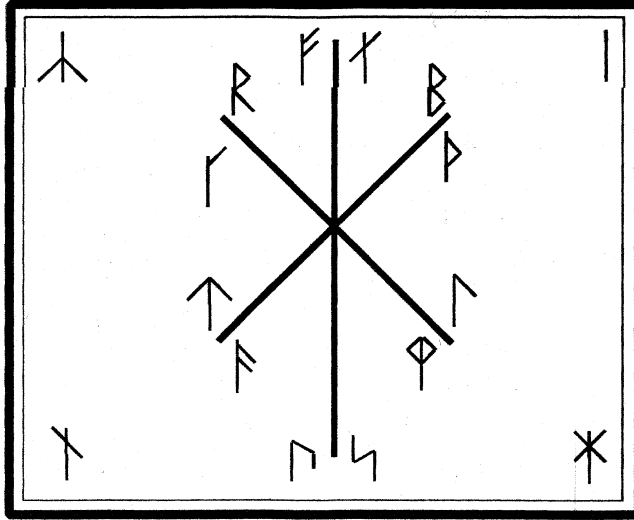

the runes and their associations as used in Stav



CONTENTS

TRY BEFORE YOU BUY	i
Details	i
Payment	i
Interested In Future Offerings?	i
FOREWORD	ii
STAV - A Brief Overview	iii
Finding Your Level / Class	iv
Levels In Stav	v
The Stances	vi
THE RUNES	1
Introduction	1
Rune Casting (Divination)	2
Fe first rune in Frey's Sett	4
Ur second rune in Frey's Sett	5
Thór third rune in Frey's Sett	6
Ás fourth rune in Frey's Sett	7
Rei fifth rune in Frey's Sett	8
Kreft a joker or wildcard	9
Hagl first rune in Heimdall's Sett	10
Nöd second rune in Heimdall's Sett	11
Is third rune in Heimdall's Sett	12
Ar fourth rune in Heimdall's Sett	13
Sol fifth rune in Heimdall's Sett	14
Tyr first rune in Tyr's Sett	15
Björk second rune in Tyr's Sett	16
Mann third rune in Tyr's Sett	17
Laug fourth rune in Tyr's Sett	18
Yr fifth rune in Tyr's Sett	19
Rune Associations ~ Summary & Overview	20
Summary of <i>'Magic'</i> Meanings (for Bind Runes etc.)	21
Other Rune Associations ~ a very brief guide	22
Hafskjöld Teaching Bindrune	22
Rune Numbers	22
Runes, Numbers and Gods Relationships	23
Basic Calendar	26
Festivals	26
Basic Clock	27
Hafskjöld Ethical Bindrune	28
Hamingja	29
Meggín	29
Önd	29
Other Associations With Stav	30
Tree Associations	30
Day Associations	30
Elements	31
Galdra and Seid Traditions	32
Reading the Futhork	33
The Nine Worlds	35
Stav Lines - Martial Arts Usage	36
FURTHER READING	37
ABOUT THE AUTHOR	37

This document consists of:

Cover Page

Contents Page

Introduction Section i to vi = 6 Pages

Main Stav Rune Notebook Section 1 to 37 = 37 pages

Rune Cast note sheet (to copy) = 1 page

Total of 46 pages

TRY BEFORE YOU BUY

DETAILS

This document is only available for download from Stav Booklets (<http://www.stavbooklets.co.uk>).

It is being made available for distribution to widen the appeal and understanding of Stav. People may be reluctant to 'take the plunge' and buy something they know little about.

That's why if you like what you read and want to keep and use this document we ask you to send payment.

If you don't wish to keep this document all we ask is that you remove it from your computer system and delete any backup and paper copy.

This document has taken time, energy, effort, money and enthusiasm to produce. Please do not abuse the distribution as this may lead to the withdrawal, or prevent future expansion, of the 'Try Before You Buy' service by Stav Booklets.

This document is designed to be viewed with Adobe Acrobat Reader and each page printed on one side A4 size paper (210mm x 297mm) with a binding on the left margin.

PAYMENT

If you wish to keep and use this document please send payment to Stav Booklets at:

10 Causeway
Thorpe Willoughby
North Yorkshire YO8 9PE
England

(Please note this is a contact address only. Do not write directly to the author using this address)

The cost of this document is **5 GB Pounds** (pounds sterling) or **8 US Dollars**.

All cheques should be made payable to M. A. Pidd and made out in GB Pounds. Cash should be sent securely via recorded delivery. Unfortunately credit card payments cannot be accepted at this time.

Please include your contact details, including e-mail address with the payment. This will allow you to be notified of any amendments to this documents and details of future offerings.

INTERESTED IN FUTURE OFFERINGS?

You can register your interest in this document, and for notification of future offerings from Stav Booklets, via the Internet at <http://www.stavbooklets.co.uk/>.

Legal Type Stuff

This is the small print. Please don't be alarmed. The author has been advised to include this section.

By downloading this document and opening this page you have agreed to the following conditions of use:

The contents of this document are not to be reproduced, duplicated, redistributed on any media, in part or as a whole. This includes inclusion in any for profit distribution and for teaching purposes. Please contact the author for the express written permission if you wish to use the contents. Use without written permission of the author establishes liability for a civil action and may give rise to criminal proceedings.

Copyright:

Copyright laws and international copyright treaties protect this document, as well as other intellectual property laws and treaties.

All title and copyrights in and to this document (including but not limited to any images, photographs and text incorporated into this document, plus any accompanying printed materials, are owned by the author.

Liability:

The author of this document is not liable for any damages whatsoever (including, without limitation, damages for loss of business profits, business interruption, loss of business information, or any other pecuniary loss) arising out of the use of or inability to use and / or implement the contents caused to the reader, or any associated 3rd parties.

The principles of Stav embodied in the document have been well tested and used. They are unlikely to cause injury or harm when used correctly and in an appropriate manner and environment. However, by downloading and using this document the reader dissolves the author of all liabilities related to this document and its use.

FOREWORD

This guide is designed to provide an introduction to Stav and the runes of the younger futhork.

Stav is a European mind, body and spirit training philosophy. It is based on the traditions of the Hafskjold family, which have been preserved in a continuous line for over 44 generations.

Advice and assistance on the study of Stav can be obtained from Einherjar Vé Stav. Contact them by sending an e-mail to info@einherjarve.org.uk or visit the site at <http://www.einherjarve.org.uk>.

Although not essential in order to gain the most from guide some previous understanding of the runes and Stav will be beneficial. This information can be found on-line at the Einherjar Vé Stav site.

It is impossible to produce a definitive book detailing all the associations, symbolism and interpretations of the runes. This may appear a contradiction as you are reading this book. However, this work is designed to start the reader onto further studies and investigation. The runes, as discovered in the web (see page 1), can be said to be part of the fabric of reality. As such they are part of everything. This means they also change as our reality, or our understanding of it, changes. This is why a book cannot begin to encapsulate the true depth of knowledge held within the runes. Only the mind has any chance of unravelling the mysteries that the runes hold, hopefully inspired and aided by the clues and general hints found in this tome.

Because of the nature of the runes this guide is therefore deliberately not definitive or absolute in its description and meaning of the runes. This is because the study of Stav involves personal interpretation and analysis. These are modified as new experiences are gained and conflicts become resolved. You will find your own comments may agree or contradict those already contained within these pages. The same rune may be interpreted slightly differently by different people or even the same person at different times and with different problems or circumstances to resolve.

You may find some of the comments and observations on the runes as terse, direct and with little explanation. This is deliberate as an attempt has been made to record only the main salient points and keywords for each rune. The descriptions of the rune meanings are only a snapshot of the author's thoughts at the time of writing; they should not be taken too literally or as a definitive guide. These are only *hints* and *reminders*; there are doubtless many other meanings and interpretations that are not included in these pages. The points and keywords that are included are intended to be used as hooks onto which further expanded explanations and details can be hung. It is expected these will be given by yourself and drawn from your own experiences and relating to the problem(s) in hand. There are no absolute answers when dealing with the meanings of the runes; there are only degrees of perception.

It is hoped that you will use this guide to augment your own personal knowledge of the runes based on your own experiences. This is not a *how-to-do-it-book* and it will not teach all the answers about Stav and the runes. That can only be achieved by patient study of the runes and the myths. However, this guide will hopefully help to form a useful stepping stone for continued studies and learning. By combining this guide with other texts, the runes and your own notes it will become an invaluable tool in the quest for knowledge and wisdom.

STAV - A BRIEF OVERVIEW

Stav has its roots in the philosophy, mythology and belief system of pre-Christian Northern Europe. Around the 8th century Christianity began to arrive in Scandinavia and soon gained considerable influence. In other parts of Europe the pagan traditions had been suppressed and the knowledge and wisdom contained there had been fragmented and would soon be lost. Thus the philosophers and priests (those of the Jarl class) were entrusted with passing on the wisdom and traditions that had been handed down to them. They devised a system for the preservation and transmission of their knowledge. This system uses a set of sixteen runes based on the Danish (or Younger) Futhork. This was considered to be the least number of runes that could provide a viable method of handing down the system. The name Futhork (or Futhark) is from the first 6 runes, Fe Ur Thór As Rei Kreft. By using the runes as a basis for a set of stances, with the body and the arms & legs moving to form the rune, the knowledge of them could be used by those whose task it was to pass the knowledge to future generations.

This system has been taught to each generation of the Hafskjold family and represents a systematic body of knowledge preserved for over 44 generations.

The word Stav is a pun, meaning both staff and rune. Stav involves use of both staff and runes in a system, which trains both the body and mind.

Stav is divided into 5 levels or classes as shown on page v. This ordered structured system fits the requirements of most men. Women are more '*free spirits*' and can belong to any class: They each have their own or can take that of their husband/partner. Women are also seen as existing in their own community independent of class. Text relating to each level and the runes is given in the *Hávamál* (Sayings of the High One), part of the Poetic Edda.

NOTE:

This system of levels/classes is not a grading or examination system but it is intended to fit your own nature and personality. It is worth noting that the grading systems for Japanese martial arts were originally introduced to control the teachers and are a bureaucratic invention. The oriental martial arts impose an artificial system of grading, not the natural ones that are used in Stav.

The objective of Stav is to achieve the best at your level. Performing the functions of your level/class and an understanding of the runes may help this. The martial arts aspect is only a small part of Stav. As with the other aspects it is not one where technique is penalised, it is the principles that are important. Techniques can be adapted to meet your own requirements.

FINDING YOUR LEVEL / CLASS

Finding your own level is through '*guided meditation*'. This is where you enter the world of the gods through a portal or doorway on which a rune is carved. The safest doorway to this is one on which the rune Tyr (a ↑ shape) has been placed. This guided meditation will reveal is your animal guide (or folgie). This folgie will help you in your journey and by association will reveal your own level/class, rune and patron god.

**This guided meditation is best first performed by a recognised teacher in Stav.
After this you can undertake your own meditation and journey with your folgie.**

The folgie may not answer direct questions, it is after all only an animal. However, it may take you to people or places where answers to your queries may be sought.

In fact people have two guides. The first one found is usually the 'good' side, the way you view yourself. The other reveals itself *when the time is right* and you have learnt enough about yourself and your interaction with others. This second folgie represents your 'darker' side, or simply how others perceive you. For example a fox may be seen as a pest and devious, cunning or manipulative. Alternatively a fox may be perceived as dignified and resourceful or lucky; these traits depend on the person to which the fox folgie relates. Other folgie will reveal different traits.

It is worth noting that *in Stav no level or class is more important than another*. Each is interdependent on the others and has responsibilities to the other levels or classes. Without the whole structure each level or class would not be able to survive in isolation. The diagram below is an attempt to show this concept.

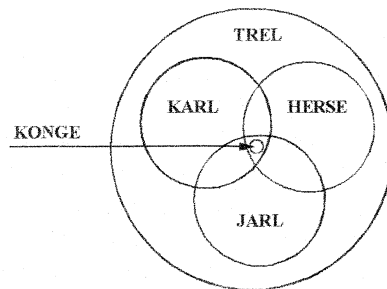

LEVELS IN STAV

TREL

Description: Serf - Dependent
Attitude: Backs away from trouble and neutralises the attack
Colour: Dark Blue / Black Element: Air
Weapon(s): Stick or Club Runes: Rei, Kreft
Hávamál: None - but trel undertakes a commitment to find own level

KARL

Description: Churl - Landowner
Attitude: Defends own property, drives away an intruder
Colour: Green Element: Earth or Water
Weapon(s): Battle Axe (Huscarl) Runes: Fe, Ar, Mann, Laug
Hávamál: *Do you know how to carve them? Do you know how to read them?*

HERSE

Description: Lord - Warrior *pronounced hashur*
Attitude: Defends society. Breaks opponents balance and controls him
Colour: Red Element: Fire
Weapon(s): Sword Runes: Ur, Thór, Sol, Tyr
Hávamál: *Do you know how to colour them? Do you know how to test them?*

JARL

Description: Earl - Priestly Class (sometimes spelt Yarl)
Attitude: Avoids getting involved. Slips past attack or neutralises threat from a safe distance
Colour: White Element: Ice
Weapon(s): Staff, Long Bow Runes: Hagl, Is, Yr
Hávamál: *Do you know how to offer them? Do you know how to pray?*

KONGE

Description: King/Wizard - Man of Knowledge *pronounced kon-yur*
Attitude: Moves in and neutralises threat before it is even carried out
Colour: Royal Blue / Purple Element: Wind - focused air
Weapon(s): Spear or any Runes: Ás
Hávamál: *Do you know how to send them? Do you know how to destroy them?*

WOMEN

Description: Women belong to all classes; they also exist as their own community
Attitude: Defends self or home
Colour: Yellow + Element: Earth
 husband/partner
Weapon(s): Stick or Battle Axe Female runes: Bjørk + Nød
Hávamál: *None*

THE STANCES

The stances are really outside the scope of this guide and only a very brief introduction is included here to give a little insight into their use and potential. The stances are significant in that the body is moved into the shape of the rune. This movement can be used as a meditation exercise and a tool for gaining further insight and understanding of the runes.

A guide to the stances can be obtained from Stav Booklets at <http://www.stavbooklets.co.uk>.

The stances are at the core of Stav. They are the embodiment of the runes through which knowledge, wisdom and enlightenment is gained. Performing the stances has many benefits including exercising the body gently and without pressure and promoting complete breathing using the whole of the lungs. A further benefit is that the stances are a *moving meditation* and can be used for relaxation and in relieving stress and tension.

When performing the stances the body is moved into the shape of the rune; both for the right and left side (right & left hand/foot lead respectively). For the right side the rune's shape should be visible to someone standing to the east and for the left side a person standing to the north. This gives the correct indication of when to turn. The scientific reason for this turning is that it allows the body to exercise for the full range of movement. The traditional (and perhaps more poetic and romantic) reason is that it allows the shape of the rune to be seen by the gods in the north and the fates in the east.

The stances are shown below (Trel and Karl level order).

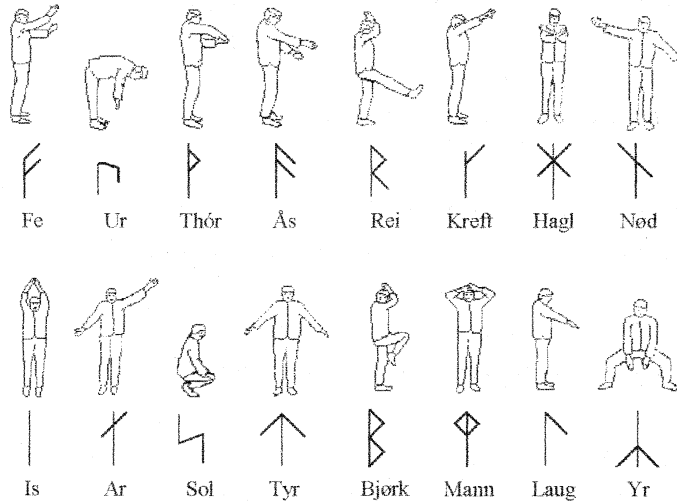

An example of an alternative stance for Sol used in the martial arts aspects or those unable to perform the normal stance as shown above.

NOTE: The position of the arms as above is not required for the stance, they should be kept at the side of the body. The drawing on the left shows how the Sol stance is used with a staff in the martial arts aspect of Stav.

The different levels or classes in Stav use different breathing techniques, different order of runes and even different body movements when performing the stances.

For further information on the stances please consult the booklet available from Stav Booklets – <http://www.stavbooklets.co.uk>.

Alternatively contact a recognised instructor in Stav. These can be found at Einherjar Vé Stav. Send an e-mail to info@einherjarve.org.uk or visit the site at <http://www.einherjarve.org.uk>.

THE RUNES

INTRODUCTION

The runes the characters of the ancient alphabet of the Germanic people. Their uses include writing, divination and magik. The runes were used throughout northern Europe, Scandinavia and Iceland. This alphabet is known as a futhork because of the initials of the first 6 characters.

The original alphabet is believed to contain 24 characters or staves. As their use evolved the English (Anglo-Saxon) futhork eventually contained 33 characters. The Scandinavian (Viking) futhork reduced to only 16 characters. It is this 16-character system, known as the Younger or Danish futhork, which forms the core of Stav. The widespread use of the runes diminished with the spread of Christianity.

The spread of Christianity in the Viking era (c9-c11) was perceived as a threat due to its repression of pagan rituals and beliefs. It is speculated that the philosophers and priests of the Viking era were entrusted with saving the wisdom and traditions that had been handed down to them. They devised the system of 16 runes for the preservation and transmission of their knowledge. Each rune would be a key for it's many associations and interpretations on many different levels.

The reduction from 24 to 16 characters also meant that a single rune would have many pronunciations and meanings depending on the circumstances and context of its use.

Whilst the actual origins of the runes have been lost the Norse myths tell of the runes being discovered by Odin. This event is described in the *Hávamál* (Sayings of the High One). They are derived from 'the web' (or the *Orlog*) which covers the universe and helps give *the lines* used in the martial and healing aspects of Stav. The web is an abstract concept existing in space and time. It can roughly be depicted by nine lines, as shown on the right. The shape of all the runes can be found in this pattern. Orlog can be translated as fate or destiny; in essence the web of reality. One can bend or negotiate the web to meet your own needs. Not to attempt this is a waste of potential. To totally ignore the Orlog, or web, is also a waste but is also seen as arrogant behaviour that may have painful consequences.

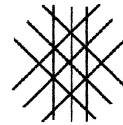

The runes are the central theme throughout Stav. Each rune has a meaning and an association with a God figure (or figures) from Norse mythology and a Stav level or class. The best way to find out about these mythological figures is to read the Edda in some of the numerous translations available (see the 'further reading' section, page 37). In addition each rune can have an associated folgie (an animal guide), tree and day. The runes and their names are shown below.

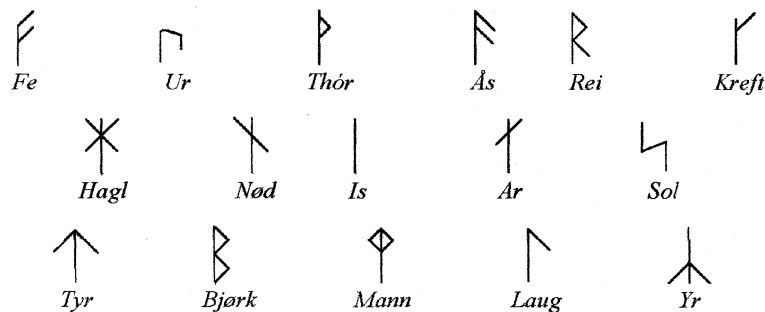

The runes are placed in 3 setts of five. Sett 1 Fe to Rei, Sett 2 Hagl to Sol and Sett 3 Tyr to Yr. The rune Krefi is not in the setts as it is a wildcard. It represents the Norse god Loki, the joker and wizard of lies. It is placed as the sixth rune in order to spell Futhork.

The runes can also be cast and read for divination (prediction or premonition). This involves reading the past, present and future for a given problem or circumstance. Further details of this aspect are given on page 2.

RUNE CASTING (DIVINATION)

The process of casting the runes is known as divination. This is a method of prediction or premonition and is basically a Karl level technique to promote an understanding of the world around and the analysis of problems and difficulties. It can also be seen as a training system to develop intuition. As is said in the Hávamál for the Karl level - *Do you know how to carve them? Do you know how to read them?*

Runes can be made of any material but preferably wood, stone or bone. For wood use those associated with the runes; Birch, Yew, Ash, Rowan, Hazel, Oak & Apple. If bone is used then ideally it should be from those of your own folgie. Stone is regarded as neutral, except for amber, which is associated with the goddess Freya. The runes are burnt or carved into the material. Alternatively they may be painted onto the material selected.

When reading runes a green headband (*vlaad*) may be worn. Attach 4 ribbons of the colour of your class / level (these are given on page v). Women can add yellow; a Konge has 4 ribbons each with the 4 colours of each class / level.

To cast hold the question or problem in mind. Do not ask direct questions, i.e. those with Yes or No answers. Instead ask leading questions, those starting with who, what, where, why, when, etc. Prior to selecting the runes you may wish to relax and focus the mind by breathing deeply nine times. Choose 3 runes at random, placing them left to right. These positions are shown below, the first selected being the past, the second is the present and the third rune signifying the future.

PAST	PRESENT	FUTURE
Root of Problem what is the cause	Reality of Problem the current situation	Probable Outcome possible actions/decisions

There are *no reversed runes in Stav*. However, you should be aware of the possible negative aspects. Each interpretation is based on the situation and the problems or events presented. Therefore the same rune may be read as having a slightly different meaning at different times and with different problems. Interpreting the runes selected requires patience and an understanding of the associations of each rune. Providing an introduction to these associations is the objective of this booklet.

Regular practice in divination is also a form of meditation. Further information on divination and other associated aspects can be obtained from Einherjar Vé Stav. E-mail info@einherjarve.org.uk or visit the site at <http://www.einherjarve.org.uk>. The people at Einherjar Vé organise regular training sessions and courses where you can discover and practice this skill.

Those more experienced and familiar with the runes may use nine runes. These are selected to give a clearer understanding of the problem(s) and possible solution(s). The nine runes are chosen at random and laid out in three rows of three. Then consecutive rows or columns are selected to represent the past present and future; i.e. past present and future may be read as rows top to bottom, bottom to top or as columns left to right or right to left. Once a decision on the order has been made then it cannot be changed once the reading has begun. The combination of attributes of the 3 runes for each of the past, present and future gives the complete rune cast.

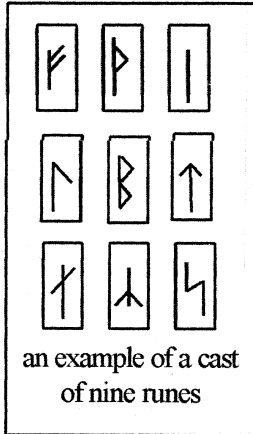

This method of selecting nine runes for a cast is not advised for the beginner. The cast is difficult to interpret and requires detailed knowledge and patience. It is used only by those more experienced when the situation warrants. The normal cast of 3 runes is sufficient for the vast majority of cases.

Other types of cast may also be performed. Some of these involve placing the runes in the shape of a 'sun-wheel' or a clock face. These other types of rune casts are outside the scope of this guide. However, there are many books available from which further knowledge can be obtained. These books are written by those specialising and more learned in this subject. Details of some of these other sources are given in the 'further reading' section.

FE

first rune in Frey's Set



God:	Frey
Folge:	Deer, Boar, Hog (swine)
Class:	Karl
Tree:	Hazel
Day:	Friday
Medicinal Tree:	Hazel
Medicinal Herb:	Barley

farming/construction aspect

Meaning: Animals. In particular domestic animals and cattle
Symbolises: Riches. Success. Fertility (peace and happiness)

Rune Rhyme

Norwegian: Money causes strife among kinsmen;
The wolf grows up in the woods

Anglo-Saxon: Wealth is a comfort for all mankind
It must be shared by he who wishes to cast his lot for judgement before the Lord

The 'wolf' is ready should any strife occur, you must be responsible and share.

Wealth and success are meaningless unless shared and freely distributed to those who have need. Signifies steady, planned growth; not many risks taken.

Connected with the fertility aspects this rune can also signify male sexuality and potency.

With the connections to fertility and harvest Frey can be seen as a sun-god, his twin sister (and counterpoint) Freya being the moon-goddess.

Fe - Possible Positive Aspects for Rune Casting Analysis

Finance & Money. Could be connected with love - or money through personal relationships (e.g. if associated with Bjork). Money should be shared around - what you offer will return multiplied. Therefore money should not be the only thing to be shared.

Foresight - a continuation, not a new start.

May indicate steady (financial) growth (e.g. safe bets – Mutual Society/Building Society/Bank, not gambled or placed on the stock exchange etc.)

Frey is associated with fertility, male potency and sex.

Fe - Possible Negative Aspects for Rune Casting Analysis

A warning not to fritter away money on personal whims or lost causes. Financial disaster may result if current path pursued. Beware of greed and 'get-rich-quick' schemes.

A loss of esteem.

Failure - bankruptcy

UR

second rune in Frey's Set



God:	Vidar
God	
Folge:	Ox
Class:	Herse
Tree:	Oak
Day:	None
Medicinal Tree:	Pine
Medicinal Herb:	Plantain

2nd strongest, silent

Meaning: Aurochs (*ancient wild ox - now extinct*)
Symbolises: Primal raw force of nature, very old, very strong.
Elemental power and energy

Rune Rhyme

Norwegian: Slag is from bad iron;
Oft runs the reindeer on the hard snow

Anglo-Saxon: The Aurochs is single minded
With horns rising high, a fierce horn fighter
Stamping his horns, a mighty being

The old Norse translations of Ur was *slag*, whereas the Anglo-Saxon meaning was *Auroch* (in Iceland it is translated as *drizzle*).

A primal force, the force of nature. Original but must be refined. Tread carefully. The most dangerous of metals but can be good or bad.

Vidar - a son of Ódin. Has a strong shoe made from leather that cobblers throw away during manufacture (alternatively this shoe is said to be iron). One of the few gods to survive Ragnarök when the world is destroyed and the old gods are killed. At Ragnarök Vidar avenges the death of Ódin. It is notable that when the god Loki insulted the other gods (known as *the Flyting of Loki*) and put himself out of their favour he didn't have a bad word to say about Vidar.

Represents a strong silent hero who keeps his own counsel. Fights and wins using other peoples cast-offs and inherits the earth because he is blameless.

Ur - Possible Positive Aspects for Rune Casting Analysis

A pioneering spirit, rugged individualism and spiritual strength

A challenge - changes in lifestyle, exciting events ahead, career prospects, generally transform for the better.

An outpouring of energy and a need to focus effort
The ability to defend - and the strength to do this
To be able to strive towards goals - and to be vigilant

Strength, Defence, Tenacity, Health

Ur - Possible Negative Aspects for Rune Casting Analysis

Faint hearted - resistance or a fear of change. Negative - prevent from progressing.

A lack of self-confidence

Beware of misdirected energy (although this may usually be linked with Rei)

Be careful not to use energy to control others.

Weakness, Obsession, Misdirection, Sickness, Dithering, Weak-Willed

THÓR

third rune in Frey's Set



God:	Thór
Folgie:	Goat
Class:	Herse
Tree:	Rowan
Day:	Thursday
Medicinal Tree:	Rowan
Medicinal Herb:	Burdock

Meaning: Thunder, War
Symbolises: Power and Protection

Rune Rhyme

Norwegian: Thurs causes the (monthly) sickness of women;
Few are (sexually) aroused at that time

Anglo-Saxon: The Thorn is very sharp, a harmful thing to grip on
Terribly harsh for anyone who rests among them

This rune may also be represented by Þ (pronounced as th). The Old English meaning of Þorn is thorn. However, in Old Norse Þurr means monster, demon, goblin, etc.. In the north-west of England the now obsolete colloquial expression *thurse* meant goblin and it is accepted this was derived from Old Norse.

This rune represents women out of balance (cursed). Another interpretation is that if you unbalance an enemy then he can be defeated. However, to overdo things also has consequences and responsibilities.

Protects, even against complacency. The rune can represent a thorn which is very sharp and offers outward protection and defence. If the thorn is turned inward on oneself the pain is a reminder to be vigilant and guard against complacency (or the easy life).

Thór - Possible Positive Aspects for Rune Casting Analysis

Protection, Good News, Good Luck (unexpected good fortune)

May suggest an important decision to be made shortly, one essential for future well-being and life-style.

A powerful rune giving protection (physical and mental) but could be discomforts in life (represented by thorn)

May gain assistance from partner/colleague.

Power, Strength, Protect

Thór - Possible Negative Aspects for Rune Casting Analysis

Caution - before decision or changes in life take advice (2nd opinion) before proceeding or complications may arise. Beware "Fools rush in...."

Could be better to do nothing rather than choose path of action.

Could indicate threat from others - business, work, parent/child, etc.. Could indicate bad relations with opposite sex (misery, pain)

Danger, Defenceless, Betrayal, Dullness

ÅS

fourth rune in Frey's Set



God:	Ódin
Folge:	Wolf, Raven, Eagle, Horse, Snake or Dragon the king must know all classes
Class:	Konge
Tree:	Ash
Day:	Wednesday
Medicinal Tree:	Ash
Medicinal Herb:	Oats

Meaning: Kingship
Symbolises: Knowledge. Communication. Spoken/Written Word. Wisdom

Rune Rhyme

Norwegian: Estuary is the way of most journeys;
But the sheath is that for swords

Anglo-Saxon: (Mouth)

The mouth is the origin of every speech,
The holder of wisdom, comfort of the wise
and hope to all who are noble

Anglo-Saxon: (Ash or Spear)

The ash reigns high, dear to men
In a firm position it well holds its place
Though many foes come to fight it

NOTE: In the Old Norse rune rhyme Ås may be translated as estuary or god.

Signifies personal responsibility; ask if it is necessary to use (unsheathe) a sword for if it is drawn then there is no other option than to use it.

Can indicate an intellectual (teacher, eternal student, etc.) or spiritual person.
Learn the way of Ódin but do not worship him (*from the Hávamál*)

Ódin is seen as a devious manipulative figure, not one to be trusted. Alternatively he's seen as just doing whatever is necessary; the end may indeed justify the means. For example, the collection of dead warriors for Valhöll / Valhalla by arranging victory or defeat in battles, often by deceitful and unscrupulous means. The warriors collected will fight at Ragnarök against the forces of evil and are Ódin's attempt at victory, thus saving himself and the old gods from destruction.

Ås - Possible Positive Aspects for Rune Casting Analysis

Wisdom, communication & learning. Wise counsel from elder/wise man.

To begin an apprenticeship - a period of learning/training. To acquire extra skills/experience to enhance existing knowledge. Could be language skills.

Unbiased & honest advice - deliberate - a second opinion before action.

Bring together diverse aspects in order to understand. Expect the unexpected (gain wisdom). Strive for the best and highest.

Inspire, Transform, Words.

Ås - Possible Negative Aspects for Rune Casting Analysis

An elder or older person causes problems. Biased advice or incorrect advice - rumours and lies.

Guard against 'smooth-talkers' and avoid 'get-rich-quick' plans & schemes from these people.

Nothing is clear - lies & rumours abound. Economical with the truth (as was Ódin). Misunderstanding.

Delusion - uncomfortable situations in the future (tests).

Beware that manipulation of others by yourself is possible. Beware not to misuse knowledge (or power) and beware of boredom.

REI

fifth rune in Frey's Set



God:	Hel	a daughter of
	Loki	
Folgie:	Red Rooster	
Class:	Trel	
Tree:	None (or all - see page 30)	
Day:	None	
Medicinal Tree:	Elder	

Medicinal Herb: Coltsfoot

Meaning: A road. A ride. A journey
Symbolises: A wild hunt (a wild ride). Death

Rune Rhyme

Norwegian: Riding it is said is worst for horses;
Reginn forged the best sword

Anglo-Saxon: Riding, for a hero within the hall is soft
More strenuous when sitting on a great horse
Journeying the long-mile roads

Even something flawed can be made good. There is always flaws in things. Recognise and accept these (any weak points are accepted). Also don't rely on things/people as this can lead to disappointment. Don't let anything surprise you and know your limits.

Can be travel, journey from home, a holiday (joy & enhance life) or a wasted effort, misdirected effort (in a tizzy - without direction/purpose)

Hel - guardian of the underworld; a place where the dead go to rest. Hel is seen as a half human and a half rotting corpse.

Rei - Possible Positive Aspects for Rune Casting Analysis

Travel - journey from home, see friends, business trip, holiday.

To gain experience - travel broadens the mind & opens up new horizons. To go to relax but also a chance to see different places and people.

Don't take the soft option or the easiest route. May indicate transport or legal jobs.

May indicate receipt of a message. A time for discussions & negotiations to start/be entered into. Could indicate taking action - starting off along a path/decision; a focused use of effort. Possibly expect justice.

Action, Justice, Ordered Growth

Rei - Possible Negative Aspects for Rune Casting Analysis

Bad or difficult journeys or delays. Miss travel connections, loose items in post, get lost, etc. May be best to postpone important trips!. May indicate a visit to a sick relative or friends in trouble in some way.

Lessons to be learned the hard way - personal sacrifices. An arduous & unpleasant journey. Better to accept positively rather than a gloomy outlook.

Don't believe everything read or heard (true facts are lost in transmission).

Possibly indicates a misdirected (unfocused) journey or effort. Life itself is a journey and this rune may suggest a life without direction and/or meaning.

Crisis, Injustice, Irrationality, Death.

KREFT

a joker or wildcard



God:	Loki (wizard of lies, trickster)
Folge:	Snake/Dragon. Monster
Class:	Trel - with potential to be a Konge
Tree:	None (or all - see page 30)
Day:	Saturday
Medicinal Tree:	Spruce
Medicinal Herb:	Wormwood

Meaning: Cancer, Canker
Symbolises: Malignancy. The left hand path. Illness - a cancer
Deceit and manipulation

Rune Rhyme

Norwegian: Sore is the curse of children;
Evil makes a man pale (as in death)

Anglo-Saxon: The flaming brand, familiar to the living enflamed
blinds with brilliance, burning most often
where the high ones are at ease

Sore is the curse of children (people) ~ something inside destroys (consumes), represents something not in balance.

Evil makes a man pale ~ something outside nature.

Loki is also god of fire, which as well as the destructive aspects is a symbol of warmth and comfort for the working man & woman.

This rune can be interpreted as people or events that are flaring or burning up. It could also indicate that people or events may be burnt, or are burning, out.

Krefth - Possible Positive Aspects for Rune Casting Analysis

A cancer/canker - a crisis or bad health

Creativity & shaping things. Inspiration, artistry, general ability & aptitude.

Energy / Strength / Positive Power / Positive Attitude

Associated with fire - temperature of person (hot/cold blood), their vitality & stamina (good health). Also fire associated with rest & relaxation (after a hard day, period of activity or stress).

Possibly be a new love - a new emotional relationship

Krefth - Possible Negative Aspects for Rune Casting Analysis

Be aware of the cancer / malignancy aspects of Krefth.

An end or termination of relationship/plans/events/etc. Growing apart in a relationship (e.g. child growing up, outgrowing one another)

Possibly clinging to a failed relationship.

Possibly lies, allegations and mistrust; although these may not be far from the truth (i.e. when Loki insults the gods)

Possibly people/events are burning up (out of control) or are burning out.

HAGL

first rune in Heimdall's Set



God:	Heimdall
Folge:	Ram
Class:	Jarl
Tree:	Yew
Day:	None
Medicinal Tree:	Beech
Medicinal Herb:	Bearberry

Meaning: Hailstones

Symbolises: Rainbow between Heaven and Earth (God and Mankind)

Rune Rhyme

Norwegian: Hail is the coldest of grains
Christ formed the world in ancient times

Anglo-Saxon: Hail is the coldest of grains
It whirls from aloft, sent by the force of the wind
Becoming water in its turn

Heimdall - The watcher, teacher and guardian (a.k.a. Rig - The Walker, the white god, golden-teeth). Chosen by Ódin to teach mankind. Fathered Trel, Karl & Jarl during his wanderings in disguise on earth. The son of Jarl is Konge. Heimdall is guardian of the rainbow bridge Bifröst, linking Ásgard to Midgard

Hail destroys crops if they're not ready or not harvested but it also refreshes and regenerates (it melts and goes into the ground to refresh the earth). As such it can be seen as an agent of fate which destroys the old and helps create the new. The Hagl rune represents universe in balance and complete. An ordered universe following the laws of nature. If these laws are worked against then everything goes out of balance.

Nature imposes certain limits and constraints - live with these and be happy.

Hagl - Possible Positive Aspects for Rune Casting Analysis

Usually indicated some kind of crisis.

Events are outside your control. Events are controlled by an outside influence.

A disruptive force - sudden and unexpected, a shock and surprise (e.g. wedding, sickness, death, etc.). May have to abandon previous plans.

Future is in the hands of an other or others or it depends on a group decision.

Hagl - Possible Negative Aspects for Rune Casting Analysis

A surprise may be unpleasant ! (try and see in the context of other runes)

Life itself is a gamble !

NØD

second rune in Heimdall's Set



God:	The Norns	
Urd	Past	old crone
Vardande	Present	mother
Skuld	Future	maiden
Folge:	Owl	Urd
	Spider	Vardande
	Carion Crow	Skuld
Class:	All	a female rune
Tree:	Ash	
Day:	None	
Medicinal Tree:	Alder	Past
	Willow	Present
	Elm	Future
Medicinal Herb:	Dandelion	Past
	Nettle	Present
	Raspberry (Strawberry)	Future

Meaning: (in) Need (of help). Crisis

Symbolises: Fate. Compulsion

Rune Rhyme

Norwegian: Need makes for a difficult situation;
The naked freeze in the frost

Anglo-Saxon: Need is a constriction on the breast
Yet often it can become a help
Bearing Omen if heed is given in time

Need/Must change and/or adapt. Need is the mother of invention. If you don't do something then there isn't a need. Try and create a need; be more than you already are and then be prepared to be tested. The Norms are the fates which test everyone.

Nød - Possible Positive Aspects for Rune Casting Analysis

Patience

Delay, constraint, limitation, ill-health, lack of money/vitality/resources - these needn't be negative (depends on other runes) as patience towards goal will be achieved.

Warning against changes - don't give up, carry on and wait for time to pass. Remain as you are now; continue (stick with) current goal/event/job/etc. until finished.

May indicate necessity - a learning situation

Nød - Possible Negative Aspects for Rune Casting Analysis

Inappropriate or misguided course of action

Against the advice of counsel / others / own conscience - inevitable failure.

Past mistake(s) catching up - reparation due (possibly treated in a way that you've treated others)

Caution about pursuing plans. May indicate not lucky in love.

IS

third rune in Heimdall's Setr

God:	Skade
Folge:	Arctic Fox, Polar Bear, Ptarmigan
Class:	Jarl
Tree:	Yew
Day:	None
Medicinal Tree:	Juniper
Medicinal Herb:	Mugwort

Meaning: Ice
Symbolises: Winter. The hunt

Rune Rhyme

Norwegian: Ice we call the broad bridge;
The blind need to be led

Anglo-Saxon: Ice is more than cold, extremely slippery, glistening glasslike
Just like a jewel, a floor formed on frost, beautiful to behold

Thick ice creates a highway but it can still break. The blind need to be led, needs to be shown the way. This is the point of Stav, to learn to look as well as see; otherwise things need explaining. The rune Is is a balanced rune.

Situation/event is frozen, static, in stasis or coolness, slippery, a danger of cutting.

Is - Possible Positive Aspects for Rune Casting Analysis

To put on ice, to delay, to freeze. Sit tight and wait. Delay is best option.

Things are best left as they are!

Is - Possible Negative Aspects for Rune Casting Analysis

Cooling off has gone too far; all emotion and enthusiasm has been lost (chilled out). Therefore cut losses and move onto other project(s) or relationship(s).

Friendship and love are difficult - no passion (heat).

Can indicate a separation with ill-feeling & resentment (family/friends/partners)

Can indicate career matters - frozen out of advancement, too static in job, etc.

AR

fourth rune in Heimdall's Setr



God:	Jord	mother of Thór
Folge:	Honey Bee	
Class:	Karl	
Tree:	Apple	
Day:	None	
Medicinal Tree:	Holly	
Medicinal Herb:	Bilberry	

Meaning: A good year. A good harvest. Fertile land
Symbolises: Plenty. The earth

Rune Rhyme

Norwegian: A good harvest is the profit of men,
I say the Lord was generous

Anglo-Saxon: The season bears hope when the God
Causes the fields to be fertile
A bright abundance for rich and poor

A need to obtain things from the land. A need to cultivate the land for reward.

Part of the Hagl rune with Nød. The good part of Hagl is Nød whereas Ar represents the bad part of Hagl.

As the rune shape suggests this is the 'flip-side' of Nød

Ar - Possible Positive Aspects for Rune Casting Analysis

Sowing fields to reap a harvest. Reward for previous actions - a fruition of plans. A successful outcome, a reward earned.

Justice in legal matters

Can indicate job/career rewards/advancement/success/etc.

Possibly indicate a marriage or other legal contract.

Can indicate a warning to be taken seriously.

Ar - Possible Negative Aspects for Rune Casting Analysis

May be a poor 'harvest' - a poor reward.

Failure - could have been prevented by greater effort.

May be on a path (course of action/project/career/etc.) not suited to.

SOL

fifth rune in Heimdall's Set



God:	Balder	the shining god
	Forsete	son of Balder, and the god of justice
Folge:	War Horse	
Class:	Herse	
Tree:	Oak	
Day:	Sunday	
Medicinal Tree:	Oak	
Medicinal Herb:	Camomile	

Meaning: The Sun
Symbolises: Peaceful Warrior. Victory

Rune Rhyme

Norwegian: The sun is the light of the lands;
I bow to the holiness

Anglo-Saxon: The sun is a symbol of hope for sea-farers
When they ferry across the fishes' bath until the
Brine-horse brings them to land

Without the sun everything is lifeless and useless. This is a good, positive rune.

Can symbolise victory in 1:1 conflict where a struggle is expected (however, see also Yr for 1:1 conflicts involving natural justice).

Sol - Possible Positive Aspects for Rune Casting Analysis

Workaholic - cannot slow down. Plays hard and works hard - a change is as good as a rest.

Sole arbiter of ones own fate.

Full of life - abundant energy, strength and a positive outlook.

Sol - Possible Negative Aspects for Rune Casting Analysis

Tension and worry - run down and drained - in need of a little rest & recuperation.

Fret & worry - but reluctant to do anything about it (stress).

Possibly indicates person who's centre of own world - someone who'll be distressed and anxious if not.

Concerns about health may be apparent and causing other problems.

TYR

first rune in Tyr's Set

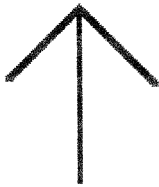

God:	Tyr the one-handed god
Folge:	Dog
Class:	Herse
Tree:	Oak (or Yew - see page 30)
Day:	Tuesday
Medicinal Tree:	Linden
Medicinal Herb:	Comfrey

Meaning: War. Justice
Symbolises: Victory. Honour

Rune Rhyme

Norwegian: Tyr is the one-handed among the Æsir,
The smith has to blow often

Anglo-Saxon: Tyr is a special sign, it keeps faith with the high ones
It always shows the correct way,
over the night sky, never failing

Lot of courage (or stupidity). What you see is what you get. Go straight (as an arrow). Work hard to get what you want; need commitment (but limits options). If loose balance then destroy everything (too many wars) and the principle is lost. Without honour there are no limits.

Can symbolise victory in a 1:Many conflict (law courts, organisations, etc.)
To do what is right - to fight for it if needs be.

Tyr rune can symbolise the sword of justice (see Yr for the scales of justice)

Tyr - Known as the one handed god as his right hand was bitten off by the giant wolf Fenris. This wolf was a son of Loki and grew so large it frightened the gods; only Tyr could approach in safety. Attempts to bind it failed until the gods made a leash of all things intangible. Before Fenris would permit them to try and bind him he insisted on an act of faith. Tyr placed his right hand in the wolf's mouth and when Fenris found he couldn't free himself and he had been tricked the wolf closed its jaws and severed Tyr's hand.

Tyr - Possible Positive Aspects for Rune Casting Analysis

Motivation - strength of will and competitive spirit. Single minded involvement in project/idea - breaks down barriers to success. Determined individual.

Increase in power and strength. Physical attraction and stamina.

To take up a just cause - a campaigner

Live to fight another day

Physical stamina and moral strength. Will do the right thing. Will fight and is confident of success

Tyr - Possible Negative Aspects for Rune Casting Analysis

A decrease in power and strength. Waning enthusiasm, failure in competition and lack of fidelity (love and friendship)

Likely to quit in the face of difficulties - not make own effort. Expects reward granted for no outlay.

Impatience

In love the current union may not be successful - no effort put into it.

Misunderstandings and difficulties.

BJØRK

second rune in Tyr's Set



God:	Frigg	wife of Ódin
Folge:	Cuckoo, Hare	
Class:	All	a female rune
Tree:	Birch	
Day:	None	
Medicinal Tree:	Birch	
Medicinal Herb:	Flax	

Meaning: Female energies
Symbolises: Magic

Rune Rhyme

Norwegian: Birch twig is the limb greenest with leaves;
Loki brought the luck of deceit

Anglo-Saxon: The Birch has no offspring, it bears twigs without seeding
Its branches shining, high in a fair crown
Laden with leaves, in touch with the sky

Björk is a woman's rune and also suggests the luck of deceit. The Birch is the first tree of spring. The birch is also used for brooms (women/witches).

The cuckoo is an intruder to others nests but is a reminder to take care of guests (whether you like them or not) and learn not to accept first impressions.

Frigg - queen of heaven. The only person, other than Ódin, permitted to sit on the high throne from which events in all nine worlds can be viewed.

This rune can symbolise health and healing. Many useful medicinal items can be obtained from the leaves and bark of the Birch.

Björk - Possible Positive Aspects for Rune Casting Analysis

Best to implement plans/schemes NOW.

Indicates tangible result - child/crops/increase in stock.

To nourish/feed/fend/care for/look after (Mother aspects). A homemaker. A project/child needs constant attention. Fortunate outcome but may need nursing.

A beginning of good fortune.

Immediate preceding or succeeding generation linked to families & family celebrations.

Associated with nursing, medicine, health care, etc.

Björk - Possible Negative Aspects for Rune Casting Analysis

Family problems and domestic troubles. Friction/disputes between family members and dearest relatives.

Unfortunate events surrounding family - worrying news or illness, child, parent, partner, wife, etc.

May indicate problems with pregnancy or conceiving children.

A new business adventure will probably fall through but could still happen later.

MANN

third rune in Tyr's Set



God:	Freya
Folge:	Hare, Cat, Lynx, Sow, Hawk / Falcon
Class:	Karl
Tree:	Apple
Day:	Monday
Medicinal Tree:	Hawthorn
Medicinal Herb:	Lilly-of-the-Valley

Meaning: Mankind. Humanity
Symbolises: Physical love. Witches. Humanity. Death. The female cycle

Rune Rhyme

Norwegian: Mankind is the increase of dust,
Mighty is the talon span of the hawk

Anglo-Saxon: Man in his mirth is precious to his kin
Yet each must fail before those he loves
For the lady will doom that unlucky flesh
To be taken by the earth

To add value to the earth (the increase of dust).

Freya - twin sister to Frey; daughter to Niörd. A counterpoint to Ódin
can symbolise the moon and sex-magic

Mann - Possible Positive Aspects for Rune Casting Analysis

Indicates a duty - gives help as part of job (doctor, accountant, nurse, etc.)

Impersonal advice, objective aid, altruistic assistance - no ulterior motive, honest and reliable.

To be able to look at own problems (own advice) but also to seek outside opinion. Power of thought - bring logic to bear on problem, to be able to look at situation dispassionately.

A belief in humanity and human rights.

Mann - Possible Negative Aspects for Rune Casting Analysis

The motive for seeking advice may be questionable.

Can expect no assistance from others. Likely to meet obstructions/subversion of aims/sabotage/etc.

Best advice is to keep a low profile - wait and watch

May be taking the wrong attitude - try and see others point of view.

May wish to cut-off from humanity - a lack of faith in the future.

LAUG

fourth rune in Tyr's Set



God:	Niörd
Folge:	Geese. Sea Birds. Sea Mammals
Class:	Karl
Tree:	Apple
Day:	Saturday
Medicinal Tree:	Apple
Medicinal Herb:	Leek (Garlic, Onion)

merchant aspect

Meaning: A bath. Water
Symbolises: Washing. Coastal waters/seas

Rune Rhyme

Norwegian: Water is that which falls from the mountain as a force;
But gold objects are costly things

Anglo-Saxon: Water to land-dwellers seems overlong
if they must travel on the galloping ships
and the waves frighten them greatly
and the brine-horse ignores the bridle

Water can be harnessed and help to create wealth (used by ships, fishing, etc. as well as by a mill). Signifies a need to do something in order to create wealth.

This is generally a positive rune.

Niörd - father of Frey and Freya

Laug is translated as *bath* (or by some as *bathe/wash*). The Scandinavian word for Saturday is lördag (laugardagr) and means 'bath-day'.

Laug - Possible Positive Aspects for Rune Casting Analysis

Be willing to follow intuition

Success in an area where imagination is used - art/design/music/writing/etc.

Be able to mould oneself into the part

The sympathy and understanding from others is involved - therefore quick conclusion to any problem(s).

Connected with learning and education - both giving and receiving.

'Go with the flow' - the tide is in your favour

Laug - Possible Negative Aspects for Rune Casting Analysis

An unlucky omen - misled by intuitions/feelings into branching into areas with no real aptitude. Attempt to develop talents not possessed - could be arts or love affair.

Don't adopt a 'wait-and-see' - immediate action required to untangle situation (but read this in the context of other runes).

Tempted to take an easy way out - a heavy price usually paid if yield to this temptation; least resistance leads to unhappiness/failure/loss of respect (self & others)

Female - timid nature (fearful). Male - treachery from women (betrayal etc.)

YR

fifth rune in Tyr's Set

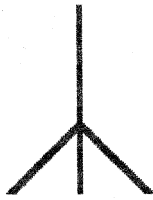

God:	Ull	the god of winter
Folge:	Fox. Bear	
Class:	Jarl	
Tree:	Yew	
Day:	None	
Medicinal Tree:	Yew	
Medicinal Herb:	Yarrow	

Meaning: Male energies. A bow (of yew)
Symbolises: Archery. Single combat. Skiing. Skating

Rune Rhyme

Norwegian: Yew is the greenest of wood in winter;
There is usually, when it burns, singeing

Anglo-Saxon: (Yew)

The Yew is outside an unsmooth tree
Hard and fast, the keeper of the fire
Upheld by deep roots, a joy to the homeland

Anglo-Saxon: (Bow)

The bow gives victory to high ones and earls
A reminder of worth, sits well on a horse
Fast in flight, fine equipment

An evergreen and old tree. A winter tree also used by man for a bow.
A hot flame can signify hot tempered ~ male enthusiasm and principle. This can be destructive, the male principle burns everything down.

There is more to it than first appears.

Ull - God of Winter. He is also seen as a guardian (protector) of the dead (yew trees are often found planted in cemeteries). The rune is seen as the scales of justice, natural justice or justice by due process (not the avenging sword of justice, or the might is right philosophy signified by Tyr).

Yr - Possible Positive Aspects for Rune Casting Analysis

Has sights set on a viable target (archer aspect of this rune) - one that is achievable. There is nothing in the way of success (the arrow will fly straight and true)

Resurrection - no matter how bad things are they will recover and come to life in a favourable aspect (winter ends and things reappear/reborn)

Natural justice, possibly in a 1:1 conflict or disagreement.

Yr - Possible Negative Aspects for Rune Casting Analysis

Hindrance - a minor catastrophe, but one that is never fully developed.

A dangerous time ahead (the winter aspect of rune - caution in the snow!)

Be aware of possible confusion or deceit.

Be aware of the possible 'hot-headed', fiery and destructive aspects of this rune .

RUNE ASSOCIATIONS ~ SUMMARY & OVERVIEW

In the table below is an overview of the rune associations. This is intended to be a quick reference guide to augment the main details given on the previous pages.

RUNE	GOD(s)	ANIMAL(s) (Folgie)	CLASS	DAY	TREE
Fe	Frey	Deer/Stag, Boar, Hog (swine)	Karl	Friday	Hazel
Ur	Vidar	Auroch (wild ox)	Herse	None	Oak
Thór	Thór	Goat	Herse	Thursday	Rowan
Ås	Ódin	Eagle, Raven, Wolf, Horse, Snake/Dragon	Konge	Wednesday	Ash
Rei	Hel	Red Rooster	Trel	None	none (or all)
Kreft	Loki	Monster, Snake/Dragon	Trel	Saturday	none (or all)
Hagl	Heimdall	Ram, Otter , Beaver	Jarl	None	Yew
Nød	The Norms: Urd Vardande Skuld	Owl Spider Carrion Crow	All	None	Ash
Is	Skade	Arctic Fox, Polar Bear, Ptarmigan	Jarl	None	Yew
Ar	Jord	Honey Bee	Karl	None	Apple
Sol	Balder Forsete	War Horse	Herse	Sunday	Oak
Tyr	Tyr	Dog / Hounds	Herse	Tuesday	Oak or Yew
Bjork	Frigg	Cuckoo, Hare, Hawk	All	None	Birch
Mann	Freya	Hawk/Falcon, Sow, Hare, Cat, Lynx	Karl	Monday	Apple or Hazel
Laug	Niörd	Geese, Sea Mammals, Sea Birds	Karl	Saturday	Apple
Yr	Ull	Fox, Bear	Jarl	None	Yew

Star Runes Notebook, A Beginners Guide ~ Try Before You Buy Edition
<http://www.starbookdata.co.uk/>

SUMMARY OF 'MAGIC' MEANINGS (for Bind Runes etc.)

Please note that these are only provided as a quick overview and are not definitive or absolute. Please use your own common-sense, understanding and judgement when consulting this list. It may be seen that the 'magic' meanings vary from those detailed on previous pages. This is yet another example of the way the meanings can change depending on their use, interpretation and circumstances.

Fe	Increase in wealth, property. Protection of valuables. Consolidate emotional relationship or sometimes hasten an affair or project onto the next stage.
Ur	Draw new circumstances into persons life. Initiate new conditions without being specific what those conditions should be (e.g. a new house but not an exact address).
Thór	Protection from ones' own folly. Luck - to be used when unable to influence result yourself in any way (e.g. medical operation - depends on the skill of the surgeon). Beware of use for females, may cause imbalance - for medical protection & healing / health Björk is a better choice for women
Ås	All matters with communication and education; learning, scholarship, teaching, negotiations, debate, public speaking/appearances, writing etc. Instil confidence, exams, job interviews, auditions, tests, quiz, etc.
Rei	Safety and comfort in travel. Satisfaction in all things associated with travel - car, plane, train, luggage, etc..
Kreft	Protection of valuables. Physical well being, self confidence. Positive, fresh starts. Stability in relationships.
Hagl	In all situations where chance involved ~ to encourage luck - see Thór
Nöd	Situations of prudence or circumspection. Good for patience, determined effort, long-term goals. Common sense and practicality. Used in love to spur relationships that are taking time getting started.
Is	To freeze, preserve, put in stasis, to hold things as they are or as any preceding runes have encouraged them to become.
Ar	When a tangible result is required in exchange for time / effort / money or trouble. The result need not be financial; can be kudos, honour or preferment. Help in legal matters.
Sol	Health. Physical strength. Clear thinking. Self confidence
Tyr	Victory through struggle. Powers of recuperation. Enthusiasm for all situations involving conflict or competition.
Björk	All domestic affairs - concerning spouse, partner, children, family, home. Birth matters to do with children generally. Female health.
Mann	Goodwill and assistance from others. Fortunate for all joint / group activities or for things intended for benefit/advancement of mankind. Also mental ingenuity and inventive ability.
Laug	Conception. Physic matters. Intuition, inner awareness. Artistic endeavour, painting, music, etc. All education linked to imagination; teaching & guidance.
Yr	Protection. Remove obstacles or change them into stepping stones for success.

OTHER RUNE ASSOCIATIONS ~ A VERY BRIEF GUIDE

There are other associations with the runes and a very brief outline of these is given in this section. A full and detailed explanation of these is outside the scope of this guide. However, the text in this section can be augmented with your own notes.

Hafskjold Teaching Bindrune

The main teaching bindrune of the Hafskjold family for Stav is based on the Hagl rune. All the other runes are then arranged around this is a set formation. The bindrune is shown below.

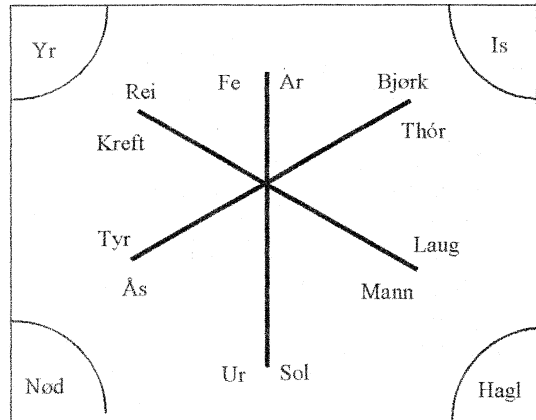

Rune Numbers

Each rune has an associated number. The basic numerology of the futhork is:-

Rune								
	Fe	Ur	Thór	Ás	Rei	Kreft	Hagl	Nod
God(s)	Frey	Vidar	Thór	Ódin	Hel	Loki	Heimdall	Norns
No.	1	2	3	4	5	6	7	8
Rune								
	Is	Ar	Sol	Tyr	Bjork	Mann	Laug	Yr
God(s)	Skade	Jord	Balder/Forsete	Tyr	Frigg	Freya	Niörd	Ull
No.	8/9	1	2	3	4	5	6	7

Runes, Numbers and Gods Relationships

The bindrune on page 22 can have other applications and interpretations.

GODS ON THE BINDRUNE

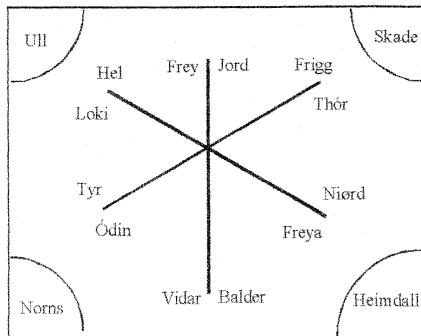

NUMBERS ON THE BINDRUNE

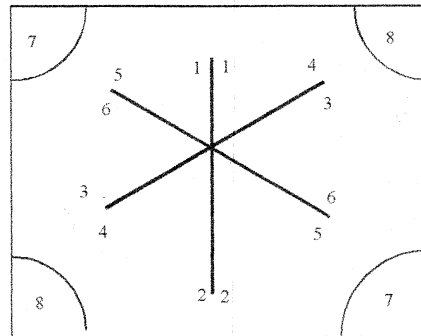

This then gives various connections between numbers, gods and the runes.

Number	Runes	Gods	Relationship(s)
1	Fe + Ar	Frey + Jord	Fertility & Earth goddesses
2	Ur + Sol	Vidar + Balder	Brothers, Gods of Peace
3	Thór + Tyr	Thór + Tyr	War Gods
4	Ás + Björk	Ódin + Frigg	Husband & Wife
5	Rei + Mann	Hel + Freya	Dark & Light moon goddesses or Death & Life
6	Kreft + Laug	Loki + Niörd	Fire & Water
7	Hagl + Yr	Heimdall + Ull	Sky gods
8	Nöd + Is	Norns + Skade	Female aspects & female energies

Star Runes Notebook: A Beginner's Guide - Try Before You Buy Edition
http://www.starbookdata.co.uk

NOTES:

The relationships given in the table on page 23 are only the author's interpretation at the time of writing. They are based on his experiences and are also taken from an understanding of other notes. There are also other numbering systems for the runes such as those based on the older futhark or their position in the setts. The books by Nigel Pennick, and Stephen E. Flowers are a useful source of information about these other systems. There are many other relationships that may be deduced. There are a few relationships that are very complex. These are left for you to meditate over.

An example of another possible relationship is Loki (no. 6) is father to Hel (no. 5) and that Niörd (also no. 6) is the father of Freya (also no. 5).

1. The gods Heimdall and Ull (runes Hagl and Yr) may be seen as 'flipsides', in much the same way the runes Nöd and Ar are flipsides of one another. An old version of the Yr rune is given below which is close to the present Hagl rune.

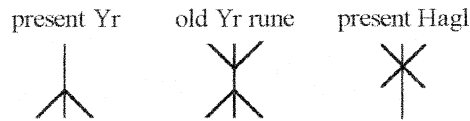

2. The gods Tyr and Thór share the number 3, which is a *magic* number in Old Norse. The god Tyr may also be included as a sky god with Heimdall and Ull. This gives a trilogy of gods and the concept of three into one is also reflected in the Valknut. The Valknut is three interlinked triangles or pyramids and is symbolic in the health and healing aspects of Stav.

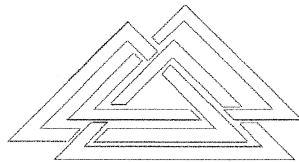

Valknut

The other common trilogy of gods in Old Norse worship was Thór, Frey and Ódin. The concept of a trilogy and three into one has echoes in other philosophies, traditions and religions. In the Christian religion it is found in the imagery of Father, Son and Holy Ghost.

It may also be worth reflecting that nine is another *magic* number in Old Norse ($3 \times 3 = 9$).

The numerology based on the bind rune can get complicated. However, there is much that it can teach. For example

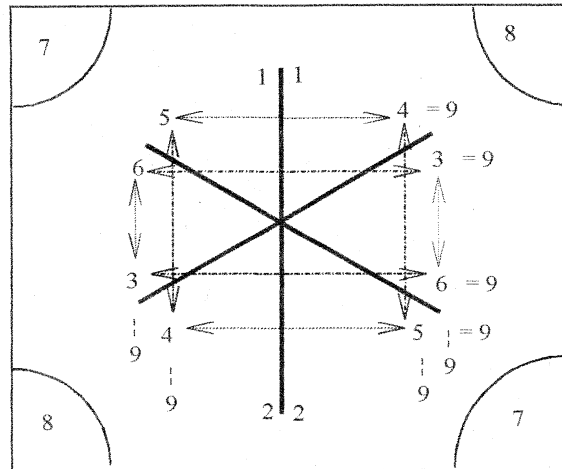

You can come to your own conclusions about why this bindrune is not balanced.

You could engineer a balanced bindrune using all eight numbers, but this may just be an academic exercise. Basically, your own guesses and perceptions based on your own understanding will be as equally valid as anything the author may write on this subject at this stage.

A study of the Old Norse myths and tables of the relationship of the gods (such as the one on page 23) can suggest that they are based on opposites, e.g. Light & Dark, Fire & Ice. It has been commented that light → darkness and darkness → light of the Norse day or year (see pages 26 & 27) can be likened to light in darkness and darkness in light of the Ying-Yang symbol (shown on the right).



It has also been commented that Fire & Ice is very close to the concept of Ying & Yang.

To add further to any confusion you may have the teaching of Stav by Ivar Hafskjold also makes the following connections between the gods.

Ódin = Ódin, Vili = Hodur and Ve = Loki

and for the Norns, **Urd = Jord, Vardande = Frigg and Skuld = Freya**

This association of the Norns is noted as a *feeling* the Hafskjold's had. These roughly equate to **Jord** as the old crone, the ancient earth, **Frigg** as the mother / housekeeper figure and **Freya** as the young and attractive maiden.

Basic Calendar

The bindrune on page 22 also allows other associations, among which is a modern calendar. Again, this is only a rough guide, which has been modified and refined. The pagan or celtic tree calendar has 13 months of 28 days (lunar cycle). Other interpretations may be possible.

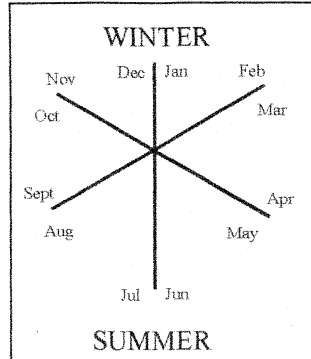

This basic calendar gives the relationship between the gods and months.

Jord.....	Jan.	Frigg.....	Feb.	Thór.....	Mar.	Niörd.....	Apr.
Freya.....	May	Balder.....	Jun.	Vidar.....	Jul.	Ódin.....	Aug.
Tyr.....	Sept.	Loki.....	Oct.	Hel.....	Nov.	Frey.....	Dec.
Ull.....	Winter	Skade.....	Winter	Heimdall...	Summer	Norns.....	Summer

Festivals

The Norse calendar gives the festivals and celebrations for each time of year.

FESTIVAL	DATE(s)	GODS
Yule (Christmas/New Year)	Dec. 23 - Jan. 7	Frey and Jord
Winter Thing (Candlemas/Imbole)	Approx. Feb. 2	Frigg and Thór
Summer Day (Mayday/Beltane)	April 30	Freya and Niörd
Baldersvaki (Midsummer Eve/Solstice)	June 23	Vidar and Balder
Summer Thing (Lamas/Lughnasadh)	August 1	Tyr and Ódin
Winter Day (Halloween/Samhain)	Approx. Nov. 2	Loki and Hel
WINTER		Skade and Ull
SUMMER		Heimdall and the Norns

Stav Runes Notebook: A Beginner's Guide - Try Before You Buy Edition
<http://www.stavbookdata.co.uk/>

Basic Clock

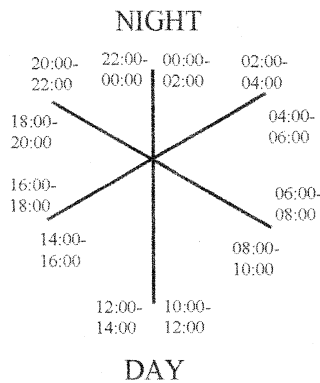

From the bindrune we can also obtain a modern equivalent for a basic clock. Note that in Old Norse an 'hour' was equivalent to 2 modern hours. Therefore the Old Norse worked with only a twelve hour day.

As with the months the association between the gods and the time of day can be established. Please note that this also is only a very rough approximation.

Frey	midnight	Hel	evening	Skade	night	Frigg	before dawn
Vidar	midday	Loki	evening	Jord	midnight	Freya	morning
Thór	before dawn	Heimdall	day	Balder	midday	Njörd	morning
Óðin	afternoon	Norns	day	Tyr	afternoon	Ull	night

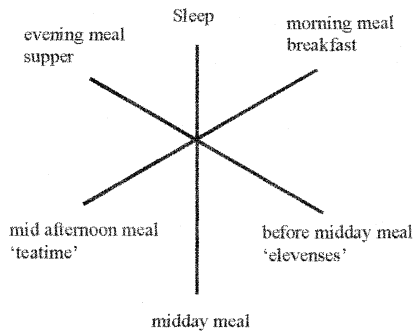

As well as the breakdown of a twenty four hour day the bindrune can be used to give the six time periods or meals of the day.

There are several mythic associations which can be made to the calendar and times of day.

For example Balder and Frey are both sun gods. Frey being the midnight sun and Balder the highest point of the sun, both at midday and at midsummer. After the zenith of Balder the sun can be seen to be heading towards darkness. This has a mythic connection in that after the death of Balder the world and the gods were heading towards the darkness and destruction of Ragnarök.

The Old Norse day began at 6 p.m., for example the start of Wednesday was on Tuesday evening. Thus Kreft (and by association the god Loki) is the first rune of night, both its beginning and its end.

The feast of Yule had 13 days, each day of the feast represented a month of the Pagan/Celtic calendar (as mentioned on page 26). This was originally the same as found in Stav. However, Stav has been updated to reflect the modern calendar with 12 months (and also the corresponding 12 days of Christmas). Remember, Stav is a dynamic system that has been modified and updated when required (even if such modifications and updates are centuries apart).

The Old Norse year was divided into just two seasons, Winter and Summer (no autumn or spring as in the milder climates of Europe). The year began with winter.

Stav Runes Notebook, A Beginners Guide - Try Before You Buy Edition
http://www.stavrunes.co.uk

Hafskjold Ethical Bindrune

The ethical bindrune is shown below.

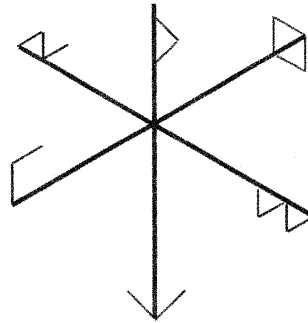

These are the only reasons for fighting and killing, as depicted on the bindrune.

Rune	Meaning
Þ	Thór Protection..... and also self defence
ᚱ	Mann Protect Selfand also to protect / defend your fellow man
ᚷ	Björk Protect Kin
↑	Tyr Protest ones beliefs, e.g. country, religion, etc.
ᚱ	Ur By fighting, even if you die, your Hamingja is kept alive. By not fighting and by accepting <i>dishonour</i> your Hamingja is destroyed.
ᚱ	Rei In some cases it is necessary to fight even if protection is impossible and you, your family, your beliefs and even your Hamingja will be totally destroyed. This is not normally necessary, but in some cases is the only option.

An example of the last concept associated with the Rei rune is drawn from the Hafskjold's own family history. They adopted the approach outlined for Rei when fighting the Nazis in the second world war. They believed it was necessary even if it destroyed their whole family line. This would leave no possibility of re-incarnation, the Hamingja being destroyed with the family.

The word *fighting*, as in the Ur and Rei runes, can be taken figuratively as well as literally. Traditionally these concepts were not just for the occasions when *fighting* was **allowed**, they were also for when it was **expected**.

There are three forces or energies which play a role in this aspect. These are Hamingja, Meggin and Önd. The various facets of these can sometimes be confusing and contradictory. A brief outline of these forces is given on the following page.

Hamingja

This can be translated as destiny, fate or luck. Hamingja runs through a family line and can appear to a greater or lesser extent in future generations. This is where the souls of the dead are reborn after a period of rest in Hel (Niflheim). How you live your life and conduct yourself has an effect on your Hamingja.

Modern science teaches the hereditary of DNA and genes which make up a family history. However, there are various aspects of a personality, mannerisms, speech patterns or phrases which can be reminiscent of grandparents and great-grandparents. Modern science has no explanation for these at this time and these traits can be put down to the Hamingja.

It may be worth noting that old Norse leaders and warriors gained a following not only for their exploits but also because they were perceived to have strong Hamingja.

Meggin

This is ones personal force or energy. A strong meggin contributes to, and allows, a health lifestyle. A weak meggin can result in sickness and ill health. Meggin can also be said to exist in all things, as an energy or force which surrounds and permeates everything. It is found in the earth, in plants and trees, in the rocks and in animals. This concept has echoes that can be found in other philosophies, traditions and religions. This force can be manipulated in 'magic' rituals and plays a role in the health & healing aspects of Stav.

When a person dies their meggin is lost, although some scholars hypothesise it may be dispersed back into the whole for reuse.

Önd

Önd is a difficult concept but put very simply it refers to the breath and spirit. It is an energy or force that is encapsulated in the human spirit. It can also be referred to as *the breath of life*.

<p>In modern times the idea of an all encompassing energy field was interpreted as <i>the force</i> used by the Jedi knights in George Lucas' Star Wars movie saga. Whether this force is like the Meggin is open to debate. It is significant that the concept of a living entities energy field is found in many widespread and different cultures.</p>

OTHER ASSOCIATIONS WITH STAV

Tree Associations

There are 7 trees or woods associated with the runes and the gods. From these the runes are traditionally carved. These woods are

Tree	Rune(s)	God(s)
Apple.....	Mann, Ar, Laug.....	Freya, Jord, Niörd
Ash.....	Ås, Nød.....	Ódin, Norms (Urd, Vardande, Skuld)
Birch.....	Björk.....	Frigg
Hazel.....	Fe.....	Frey
Oak.....	Tyr, Sol, Ur.....	Tyr, Balder / Forsete, Vidar
Rowan.....	Thór.....	Thór
Yew.....	Is, Hagl, Yr.....	Skade, Heimdall, Ull

The rune Rei, associated with the goddess Hel, is a little outside tradition. It may be carved from Ash, Apple or indeed any of the other woods.

The Krefth rune, associated with the god Loki is also similar to Rei in that it can be carved from Ash or any of the other woods.

The Tyr rune, associated with the one-handed god Tyr, was traditionally carved from Yew. However, as a warrior god a modern interpretation is that Oak may be used.

The rune Mann may also be carved from Hazel.

It may be worth noting that Ash represents the World Tree - Yggdrasil.

In terms of the levels/class in Stav the following associations can be made

Level/Class Tree(s)

Trel / Thrall	Any (associated with Rei and Krefth)
Karl.....	Apple, Hazel
Herse.....	Oak, Rowan
Jarl.....	Yew
Konge.....	Ash
Women.....	Birch

Day Associations

Day	Rune(s)	God(s)
Monday.....	Mann.....	Freya
Tuesday.....	Tyr.....	Tyr
Wednesday.....	Ås.....	Ódin
Thursday.....	Thór.....	Thór
Friday.....	Fe.....	Frey
Saturday.....	Krefth / Laug.....	Loki / Niörd
Sunday.....	Sol.....	Balder / Forsete

Elements

There are five elements, Earth, Water, Fire, Ice and Air. These are linked with the different levels or classes of Stav (see page v).

Element	Level/Class	Colour
Earth - unfocused air	Trel or Thrall	Black / Dark Blue / Brown (barren earth)
Water	Karl	Green
Fire	Herse	Red
Ice	Jarl	White
Wind - focused air ...	Konge	Black/Purple/Dark Blue/etc. (stormy sky)

These elements can be arranged in many ways, for example on the body:-

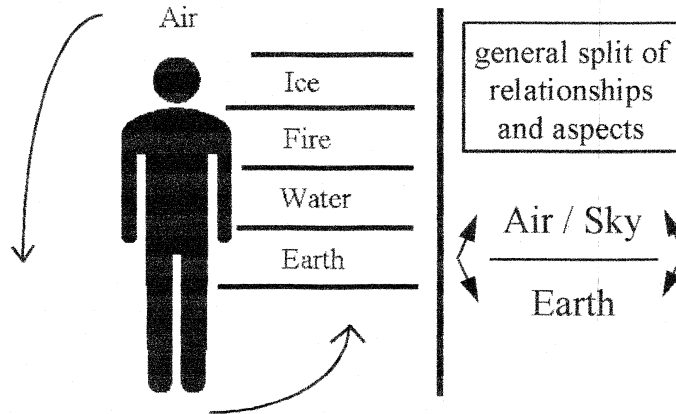

The Trel / Konge can be seen as opposites and also one and the same. Other examples of how these elements can be arranged are:-

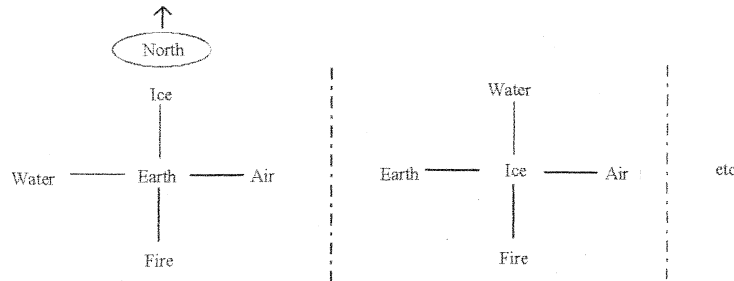

A final example given here of how the elements can be arranged is around a pentagon, star or pentagram. There are many other arrangements that you can discover for yourself.

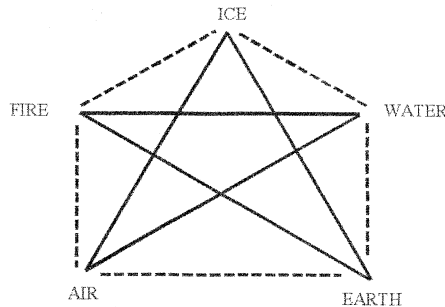

Stav Runes Notebook, A Beginners Guide -- Try Before You Buy Edition
<http://www.stavbooks.co.uk/>

Galdra and Seid Traditions

There are two main traditions in Stav. These are Galdra (sometimes spelt Galder) and Seid (sometimes spelt Seidr). As might be deduced from the association of the gods these two traditions are often contradictory.

- Galdra masculine, or really an Æsir tradition.
- Seid feminine, or really a Vanir tradition.

Seid stresses the importance of links with the earth as a whole, e.g. land, sea, sky, nature, etc. Galdra stresses other concepts and is associated with the sky, male energies and other associated interests. Galdra can be said to reflect spiritual, cerebral and ethereal matters. The Trel/Thrall link with the earth is a Galdra one, not a Seid approach.

Seid is especially a woman's tradition but it is also important to men of the Karl level/class. Men of the this level/class can partake of some of the Seid aspects in their use of divination and the medicinal and health aspects of Stav. Traditionally a Seid approach does not use the runes. However, the divination of the Karl level/class can be seen as an exception to this and explains its use by males. This link of men to the Seid tradition is also a link with the Vanir traditions. The colour associated with Seid / Women is yellow or gold.

It has been suggested that fire and air are Æsir based elements and that earth and water are Vanir based elements. The element ice can be viewed as neutral between the two. However, this is debatable and is only one view of this concept. At least one translation of the Edda suggests the Vanir are primeval gods of the air and water, which is subtly different from the statement linking them with earth and water. This split between air / sky and the earth is also expressed in the various relationships with the elements and runes, as shown in the diagram on page 31. In this there are no absolute right or wrong answers, only your own perception, intuition and insight. These are perfectly valid as long as they work. This notebook is designed to be augmented with your own views, comments and research to enable you to come to your own conclusions.

Reading the Futhork

As stated earlier the futhork used for Stav is the Danish or Younger futhork. The name Futhork (or Futhark) is from the first 6 runes, Fe Ur Thór Ás Rei Kreft. The Ás rune is pronounced as Óss, this also accounts for the different spellings of futhork and futhark.

































































Each level/class in Stav have their own way of reading the futhork. The stances associated with each rune are performed by each level/class in the order that they are read.

Each level/class has its own unique way of breathing and moving the body when performing the stances. The stances are outside the scope of this booklet. Recognised Stav tutors can teach the different methods of performing the stances. Instruction for the stances and breathing used by the different levels are given to individuals at regular training sessions. Instructors can be found at Einherjar Vê Stav. Send an e-mail to info@einherjarve.org.uk or visit the site at <http://www.einherjarve.org.uk>.

The different ways of reading the futhork for each level/class are given below. For each level/class these should be read left to right, top and then bottom row.

Level Order

Trel Traditionally the Trel did not read the futhork in any order. However, modern Stav as defined by Ivar Hafskjold teaches the Trel stances as those of the Karl level with a breathing technique based on the Konge.

Karl								
								
Herse								
								
Jarl								
								
Konge								
								

Those more perceptive may have noticed a repeating pattern of three groups, the order being changed for each level or class. The futhork is based on the concept of three setts or families. This idea has echoes of the three into one concept of the Valknut and other trilogies briefly outlined on page v.

The three setts are named after the god associated with the first rune in the sett. The setts are also associated with the class or level of the god after which they are named. The rune Kreft is the wild-card or joker and is omitted from the sett structure. However, as can be seen from the stances, in practice Kreft is almost always appended to the end of the Frey sett (as stated on page 33 this also allows Frey's sett to spell Futhork). The setts are:-

Name: Frey's Sett also referred to as Sett 1

Runes: 

Class/Level: Karl

Name: Heimdall's Sett also referred to as Sett 2

Runes: 

Class/Level: Jarl

Name: Tyr's Sett also referred to as Sett 3

Runes: 

Class/Level: Herse

Odd one this is the Kreft rune - this rune is usually out: appended to the end of Frey's Sett.



Class/Level: Trel

Each sett has its own mythical, spiritual and runic associations and meanings that are outside the scope of this brief guide. However, this booklet is designed to be expanded with the results of your own investigations and research. For further information consult some of the various books available. Alternatively contact a recognised instructor in Stav. These can be found at Einherjar Vé Stav. Send an e-mail to info@einherjarve.org.uk or visit the site at <http://www.einherjarve.org.uk>.

The Nine Worlds

The nine worlds from the Norse myths can be arranged around the Hagl rune with Midgard at the centre as shown below.

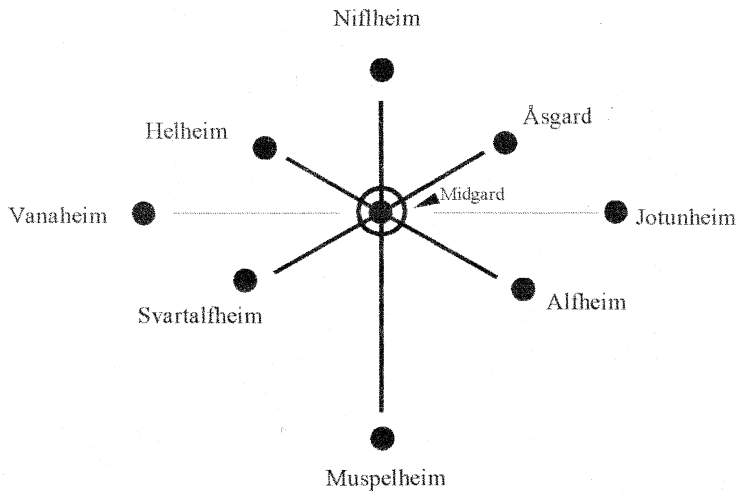

A definitive list of the nine worlds is difficult to establish from the various translations of the Edda. This is because many of the worlds named may only be suburbs or regions of another. For example some see Niflheim as a region of Hel where the evil dead go to be punished by having their corpses chewed by the serpent Nidhog. Others just see Niflheim as an alternative name for Hel.

In some instances it is in fact easier to reduce the number of worlds to seven and arrange them around the points of the Hagl rune, with Midgard at the centre.

Stav Lines - Martial Arts Usage

A final example of the use of the Hagl rune is its use in the martial arts aspects of Stav. Each line of the Hagl is used by a level/class and the principle adopted in the martial art aspect is indicative of the level/class.

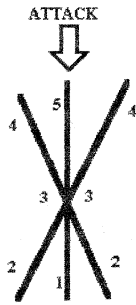

- 1 TREL level Back off and then move in
- 2 KARL level Stops and drives attacker away
- 3 HERSE level Takes control of an attacker
- 4 JARL level Avoid attack or neutralise it
- 5 KONGE level Breaks attack before it starts

The Hagl rune is also used to define the lines an attacker uses to cut or strike an opponent. This is difficult to represent here, as it is a 3-dimensional concept defining lines through the body. This idea of the lines can also be described as a 4-dimensional or 5-dimensional concept; the lines being both in space and time.

Put very simply the main attack lines are down through the body's centre and from shoulder to the opposite hip on either side. On a smaller scale they may be represented on the face, down through the nose and from temple to the side of the jaw on the opposite side. These lines can be seen to reflect the web, as shown on page 1. The diagrams below attempt to show these lines, the central Hagl is emphasised.

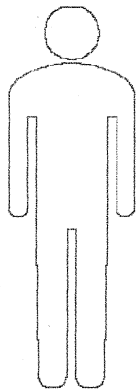

Without Lines

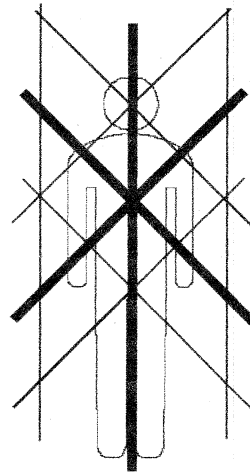

With Lines

Stav Runes Notebook, A Beginners Guide - Try Before You Buy Edition
<http://www.stavrunes.co.uk>

FURTHER READING

The books listed below are drawn from the author's own library and are suggestions for further reading into the myths and poetry of the Viking era from which Stav has its roots. A list of other books can be found at the Stav Booklets web site <http://www.stavbooklets.co.uk> or the Einherjar Vê web site <http://www.einherjarve.org.uk>.

<i>Penguin Book of Norse Myths</i> - Kevin Crossley-Holland.....	<i>Penguin</i>	ISBN: 0-14-017993-3
<i>An Introduction to Viking Mythology</i> - John Grant.....	<i>Grange Books</i>	ISBN: 1-85627-830-1
<i>The Norsemen</i> - H. A. Guerber.....	<i>Senate</i>	ISBN: 1-85958-014-9
<i>Edda</i> - Snorri Sturluson (translated by Anthony Faulkes).....	<i>Everyman</i>	ISBN: 0-460-87616-3
<i>Prose Edda</i> - Snorri Sturluson (translated by Jean I. Young).....	<i>University of California Press</i>	ISBN: 0-520-01232-1
<i>Norse Poems</i> - W. H. Auden / J. P. Taylor.....	<i>Athlone Press</i>	ISBN: 0-485-11226-4
<i>Poems of the Elder Edda</i> - Patricia Terry.....	<i>University of Pennsylvania Press</i>	ISBN: 0-8122-8220-5
previously published as <i>Elder Edda of the Vikings</i>	<i>Bobbs-Merrill</i>	ISBN: 0-672-60332-2
<i>Hammer of the North</i> - Magnus Magnusson.....		ISBN: 0-85613-301-9
<i>Rune Magic</i> - Nigel Pennick.....	<i>Aquarian</i>	ISBN: 1-85538-105-2
<i>The Galdrabók</i> - Stephen Flowers.....	<i>Weiser</i>	ISBN: 0-87728-685-X
<i>Practical Magic in the Northern Tradition</i> - Nigel Pennick.....	<i>Thoth</i>	ISBN: 1-870450-16-7
<i>The Runes</i> - Bernard King.....	<i>Element</i>	ISBN: 1-85230-420-0
<i>Runes</i> - R.I. Page.....	<i>British Museum Press</i>	ISBN: 0-7141-8065-3
<i>Asgard and the Norse Heroes</i> - Katharine K. Boulton.....	<i>Everyman</i>	pub. c1900, No ISBN

ABOUT THE AUTHOR



Alex Pidd was born in 1962 in a small town in Lincolnshire, England. His regular job is a Systems Engineer for a major social alarm company. Please forgive the unflattering id photograph on the left.

He has been studying Stav since the middle of 1995, attended regular training sessions and summer courses to further his understanding and knowledge of Stav. His tutors include Graham Butcher, Mark Siddall and Martin Render. These tutors have a direct line to Ivar Hafskjold, from whose family tradition Stav originates.

Alex has been able to incorporate Stav principles when gaining NCFE qualifications in counselling skills. Other certificates include basic adult education teaching.

His other interests include riding his motorcycle (mainly because it is old and slow), going to the movies and the occasional glass of good Scotch whisky. It is also rumoured he like cats.

Alex has been producing documents and booklets on Stav based on his own notes and studies since starting this practice. Making them available via the Internet is his way of distributing the information on Stav to a wider audience. I hope you will support his endeavours.

If you have any quick questions for Alex you can send an e-mail to questions@stavbooklets.co.uk.



1st Edition ~ 2nd Issue (A4) ~ April 2001 ~ Copyright © 2001 MAP
previously printed & available as an A5 booklet 1996-1999

Based on the teachings of Ivar Hafskjold and other original research.
With special thanks to Ivar Hafskjold, Mark Siddall, Martin Render and Shaun Thorpe for their encouragement, comments and notes.



The contents of this document are not to be reproduced, duplicated, redistributed on any media, in part or as a whole. This includes inclusion in any for profit distribution and for teaching purposes.

Please contact the author for the express written permission if you wish to use the contents.

Use without written permission of the author establishes liability for a civil action and may give rise to criminal proceedings.

DATE: **CAST FOR:**

QUESTION:

CAST: PAST **PRESENT** **FUTURE**

NOTES:

DATE: **CAST FOR:**

QUESTION:

CAST: PAST **PRESENT** **FUTURE**

NOTES:

DATE: **CAST FOR:**

QUESTION:

CAST: PAST **PRESENT** **FUTURE**

NOTES:

DATE: **CAST FOR:**

QUESTION:

CAST: PAST **PRESENT** **FUTURE**

NOTES:
